



4

RECEPTION MIRÓ



5

RECEPTION MIRÓ



6

RECEPTION MIRÓ



7

RECEPTION MIRÓ





12

OPERA



13

OPERA



14

OPERA



15

OPERA



Es la respuesta al deseo de tener algo único, diferente, original.

Los materiales y combinaciones cromáticas que ofrece, hacen de Miró un mueble de tendencia que enfatizan el artista encerrado en cada uno de nosotros





18

MIRÓ



19

MIRÓ















De la palabra griega que significa forma, aspecto exterior, nació la idea de esta línea. Eidos es joven, dinámica. Se adapta a cualquier espacio dando un toque de frescura al ambiente.

Ideal para áreas de trabajo con escasa iluminación, proyectos contract o home office









Es la respuesta a la necesidad de muebles económicos pero funcionales y con buen contenido estético. Múltiples soluciones que se adaptan a todo tipo de espacio, amigable hasta en su sistema de armado.

Kamos es la solución perfecta para proyectos con presupuesto limitado o con necesidad de entrega rápida









Es la respuesta a la necesidad de muebles económicos pero funcionales y con buen contenido estético. Múltiples soluciones que se adaptan a todo tipo de espacio, amigable hasta en su sistema de armado.

Kamos es la solución perfecta para proyectos con presupuesto limitado o con necesidad de entrega rápida









VIDRIOS



METALES

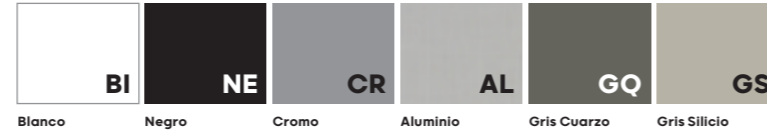

LAMINADOS

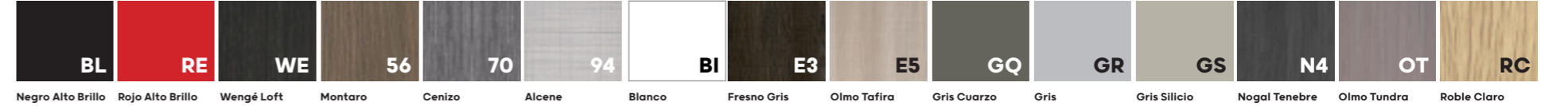

MELAMINAS

Modelo	BI	GQ	BI	NE	CR	AL	GQ	GS	BL	RE	WE	56	70	94	BI	E3	E5	GQ	GR	GS	N4	OT	RC										
RECEPTION MIRÓ	Cubierta mostrador								Vistas	Vistas								Cuerpo y Cajonera						Vistas	Vistas	Vistas							
EIDOS																											Cubiertas, Puertas y Top						
KAMOS PURE								Soporte cajonera										Gabinetes									Escritorios, Mesas, Cajoneras, Puertas, Costados y Top	Escritorios, Mesas, Cajoneras, Puertas, Costados y Top	Escritorios, Mesas, Cajoneras, Puertas, Costados y Top				
KAMOS PLUS																											Escritorios, Mesas, Cajoneras, Puertas, Costados y Top	Escritorios, Mesas, Cajoneras, Puertas, Costados y Top					
TOWER EVO		Cubierta escritorio																Gabinetes									Cubiertas, Cajoneras, Credenzas, Puertas, Costados y Top	Cubiertas, Cajoneras, Credenzas, Puertas, Costados y Top	Bases de Mesas de Juntas y Gabinetes Abiertos	Bases de Mesas de Juntas y Gabinetes Abiertos			
OPERA																			Gabinetes								Cubiertas, Cajoneras y Libreros	Cubiertas, Cajoneras y Libreros	Boiserie	Boiserie			
MIRÓ																														Cubiertas, Top y Puertas	Cubiertas, Top y Puertas	Cubiertas, Top y Puertas	Cajoneras, Credenzas, Top y Puertas

RECEPTION MIRÓ

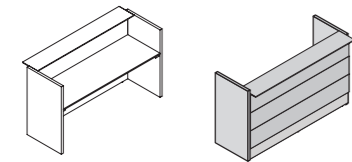

L	1.68 / 2.08
F	0.64
A	1.10

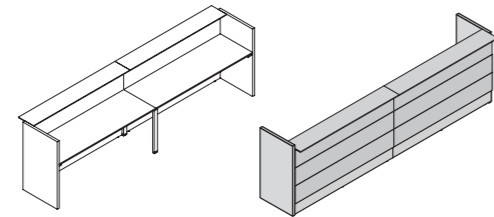

L	3.28 / 4.08
F	0.64
A	1.10

L	=	LARGO
F	=	FONDO
A	=	ALTURA

OPERA

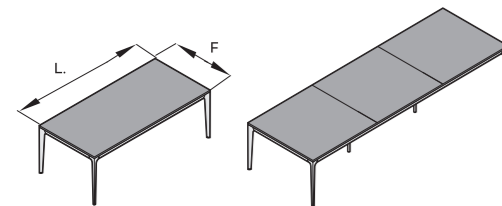

L	2.10
F	1.00

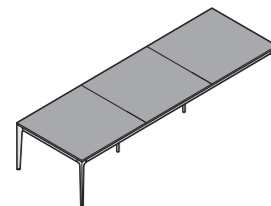

L	3.60 (3 x 1.20)
F	1.20

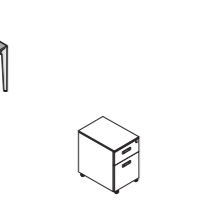

L	0.42
F	0.56
A	0.60

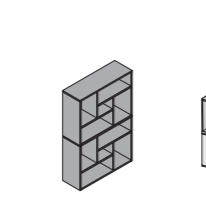

L	0.81
F	0.27
A	1.17

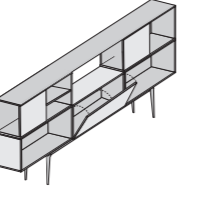

L	2.70
F	0.38
A	1.26

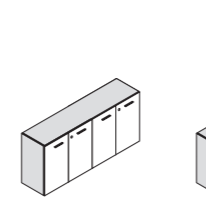

L	1.80
F	0.46
A	0.82

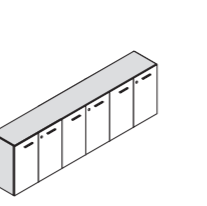

L	2.70
F	0.46
A	0.82

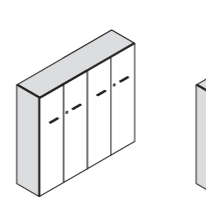

L	1.80
F	0.46
A	1.62

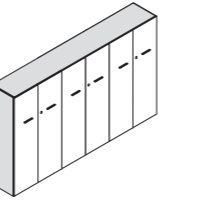

L	2.70
F	0.46
A	1.62

MIRÓ

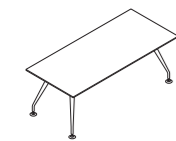

L	1.80 / 2.00
F	0.90

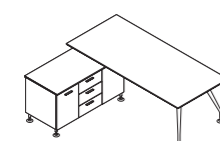

L	1.80 / 2.00
F	1.80

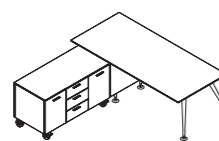

L	2.00
F	1.95

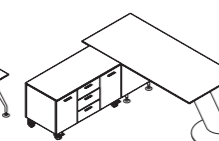

L	2.00
F	1.95

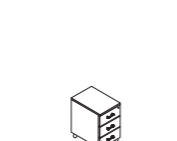

L	0.43
F	0.53
A	0.66

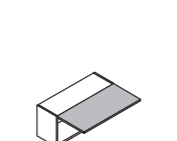

L	0.90
F	0.33
A	0.44

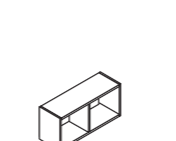

L	0.90
F	0.33
A	0.44

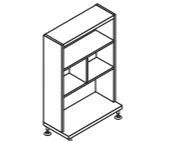

L	0.90
F	0.31 / 0.44
A	1.42

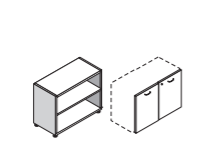

L	0.90
F	0.46
A	0.82

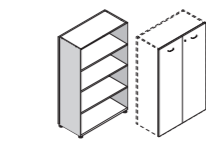

L	0.90
F	0.46
A	1.62

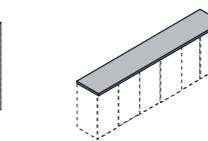

L	0.90 / 1.80
F	2.25 / 2.70

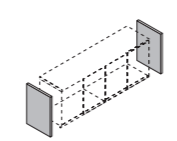

A	0.80
---	------

TOWER EVO

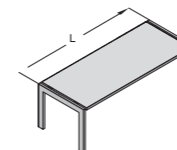

L	1.80
F	0.90

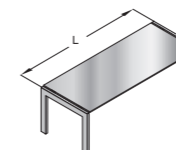

L	1.80
F	0.90

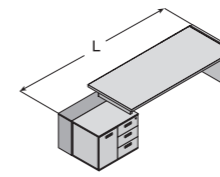

L	2.15
F	0.90

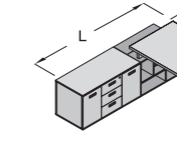

L	2.01
F	2.10

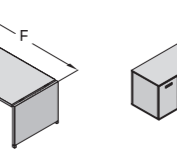

L	2.01
F	2.10

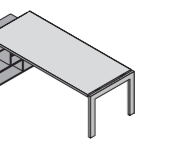

L	2.01
F	2.10

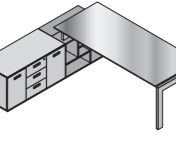

L	2.01
F	2.10



L	0.42
F	0.56
A	0.60

L	=	LARGO
F	=	FONDO
A	=	ALTURA

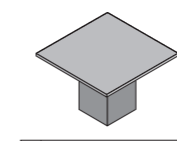

L	1.10
F	1.10

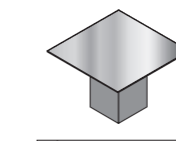

L	1.10
F	1.10

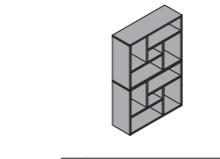

L	0.81
F	0.27
A	1.17

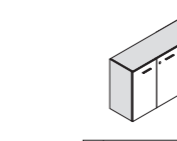

L	1.80
F	0.46
A	0.82

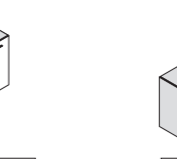

L	2.70
F	0.46
A	0.82

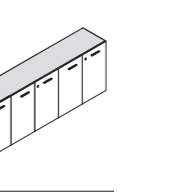

L	1.80
F	0.46
A	1.62

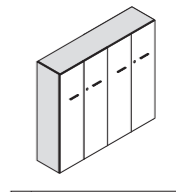

L	1.80
F	0.46
A	1.62

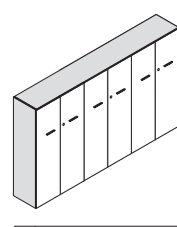

L	2.70
F	0.46
A	1.62

EIDOS

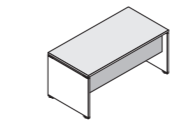

L	1.60 / 1.80
F	0.80

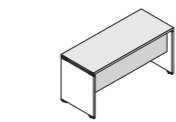

L	1.20
F	0.60

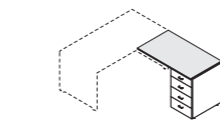

L	1.00
F	0.60



L	0.90
F	0.31 / 0.44
A	1.42

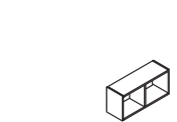

L	0.90
F	0.33
A	0.44

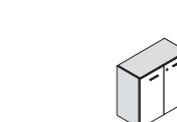

L	0.90
F	0.46
A	0.82

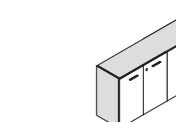

L	1.80
F	0.46
A	0.82

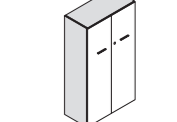

L	0.90
F	0.46
A	1.62

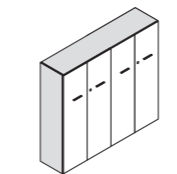

L	1.80
F	0.46
A	1.62

KAMOS PLUS

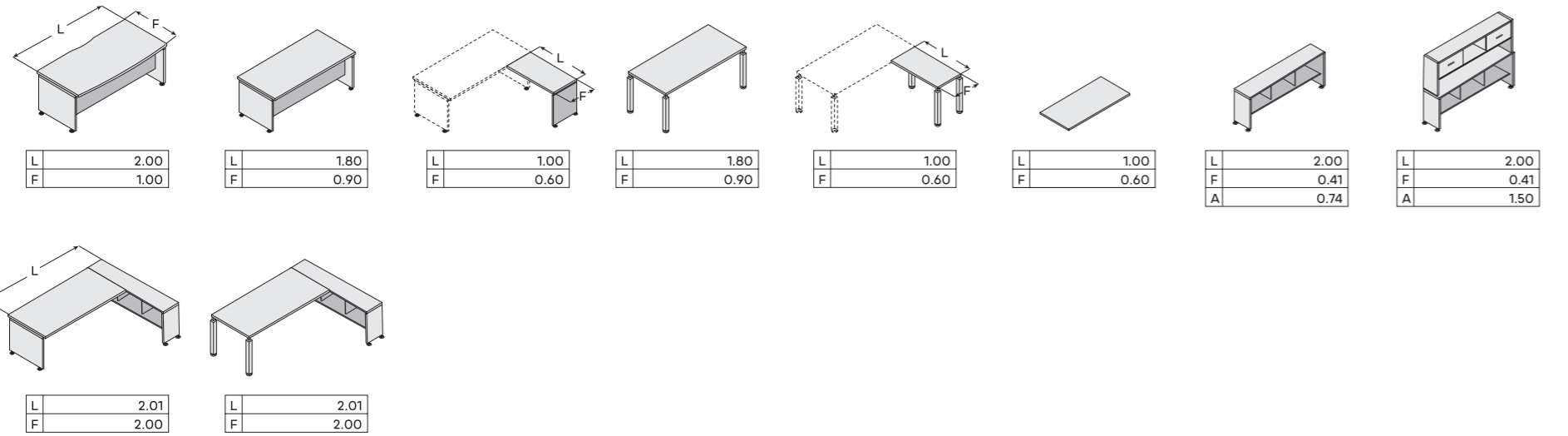

L	=	LARGO
F	=	FONDO
A	=	ALTURA

ELEMENTOS COMPARTIDOS KAMOS PLUS & PURE

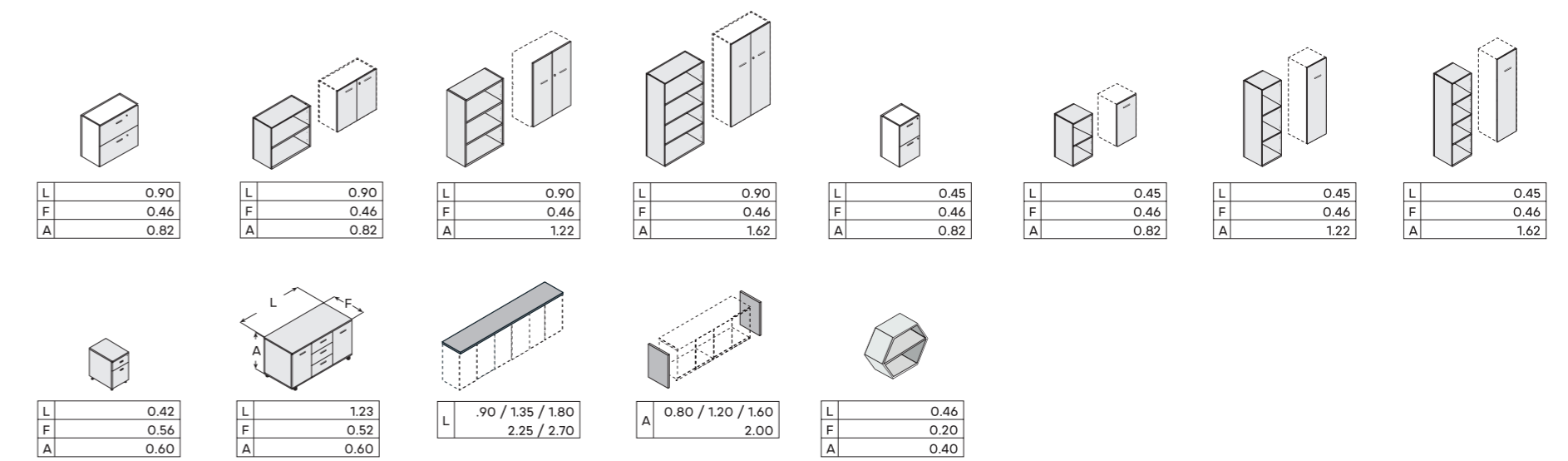

L	=	LARGO
F	=	FONDO
A	=	ALTURA

KAMOS PURE

